



## Dual Tandem Gooseneck Dump Trailer



Artwork for illustration use only.

### Standard Features

<b>GVWR</b>	20,000 lb.	<b>Spare Tire Mount</b>	Located in Gooseneck
<b>Coupler</b>	2 <sup>5</sup> / <sub>16</sub> " Ball Std. Adjustable Pipe	<b>Wheels</b>	16" x 6" Dual Wheels
<b>Safety Chains</b>	<sup>3</sup> / <sub>8</sub> Grade 70 w/Safety Latch Hooks (2 ea.)	<b>Dump box</b>	10 ga. Steel
<b>Jack</b>	(2) 12,000 lb. Drop Leg Jacks	<b>Lights</b>	D.O.T. Recessed, Rubber Mounted
<b>Neck</b>	12" x 19 lb. I-Beam	<b>Break-Away System</b>	Meets D.O.T. Specifications
<b>Frame</b>	12" x 19 lb. I-Beam	<b>Safety Marker Tape</b>	Meets D.O.T. Specifications
<b>Cross Members</b>	3" I-Beam @ 18" centers	<b>Electrical</b>	6-Way Insulated Cable
<b>Axles</b>	(2) Dexter 10,000 lb. Dual Wheel Electric Brake Axles with Oil Bath	<b>Finish (prep)</b>	White Phosphorus Washed, Primed 100% Complete with PPG VAP904
<b>GA.W.R. (each axle)</b>	10,000 lb.	<b>Paint</b>	100% (2) Coat System, PPG Industrial Coating, High Grade Finish
<b>Suspension</b>	Dexter 20K		
<b>Tires</b>	750 x 16 Loadrange D		





# Dual Tandem Gooseneck Dump Trailer

...Call for Pricing

## Trailers:

8' x 16' x 2' Sides\*\* .....  
8' x 18' x 2' Sides\*\* .....

## Axle Upgrades:

10K Vac/Hyd Drum .....  
10K Vac/Hyd Disc.....  
12K Electric.....  
12K Vac/Hyd Drum .....  
12K Vac/Hyd Disc .....  
12K Air (1 ABS) .....  
15K Electric\*\*\* .....  
15K Vac/Hyd Drum\*\*\* .....  
15K Air (1 ABS)\*\*\* .....  
Hutch Suspension .....  
Electric/Hydraulic Kit .....

## Additional Upgrades:

3' Solid Sides .....  
4' Solid Sides .....  
Dump Gate .....  
Slide-in Ramps w/ Storage .....  
LR26 (12 ton) to LR28 (15 ton) .....

\*\* Trailer is equipped with Rugby LR26 (12 ton) upgraded hoist and power unit.

\*\*\*15K Includes (8) 215x75Rx17.5 - 16 Ply Tires

## Tire & Wheel Upgrades:

(8) 10 Ply Bias .....  
(8) 10 Ply Radial .....  
(8) 14 Ply Radial .....  
Spare 8 Ply Bias .....  
Spare 10 Ply Bias .....  
Spare 10 Ply Radial .....  
Spare 14 Ply Radial .....  
Spare 215x75Rx17.5 16 Ply .....

Prices Subject to Change Without Notice

F.O.B. San Antonio, TX.

*The bitterness of poor quality remains long after the sweetness of low price disappears.*



# *Southwest Gooseneck*

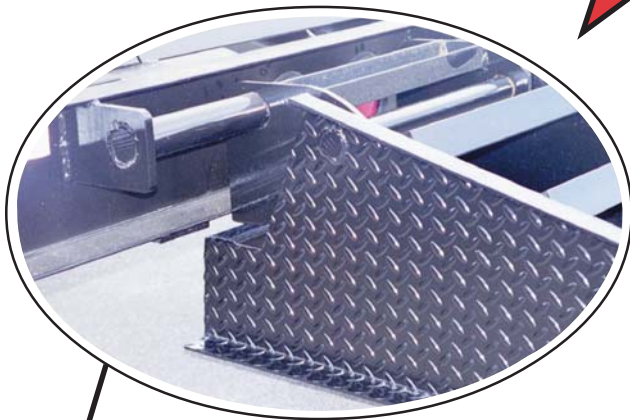

Intergrated Ramp Support



Flatbed Tie down (optional)

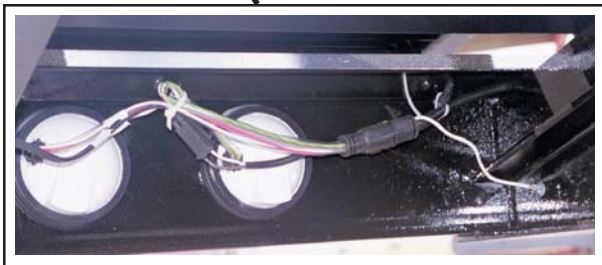

Phillips Sta-Dry Wire Harness



Combination Stake Pockets & D-Rings (optional)



3" Mini I-beam crossmember  
3/16" solid gusset with 1" bend



Dexter axles with 3" heavy duty rubber bushed suspension



## ELECTRICAL Tips and Diagrams

### Wire Installation Tips

By law, trailer lighting must be connected into the tow vehicle's wiring system to provide trailer running lights, turn signals and brake lights. This is accomplished by tapping into the tow vehicle's harness power to the trailer wiring system. Connectors are used between the two to allow disengagement when not towing.

### Connectors

Various styles of connectors are available with four to seven pins to allow transfer of power for the lighting as well as auxiliary functions such as electric trailer brake control, backup lights, etc. Choose a connector that has the required number of pins for the functions required. The male end is mounted on the vehicle side and the female end on the trailer side.

### 6 Way Connectors

Round 1 1/4" diameter metal conductors are available that allow 1 or 2 additional functions such as back up lights and electric brakes.

### 7 Way Connectors

Additional pins for auxiliary power, trailer battery charging, etc. are available using larger 2" diameter, round connectors.

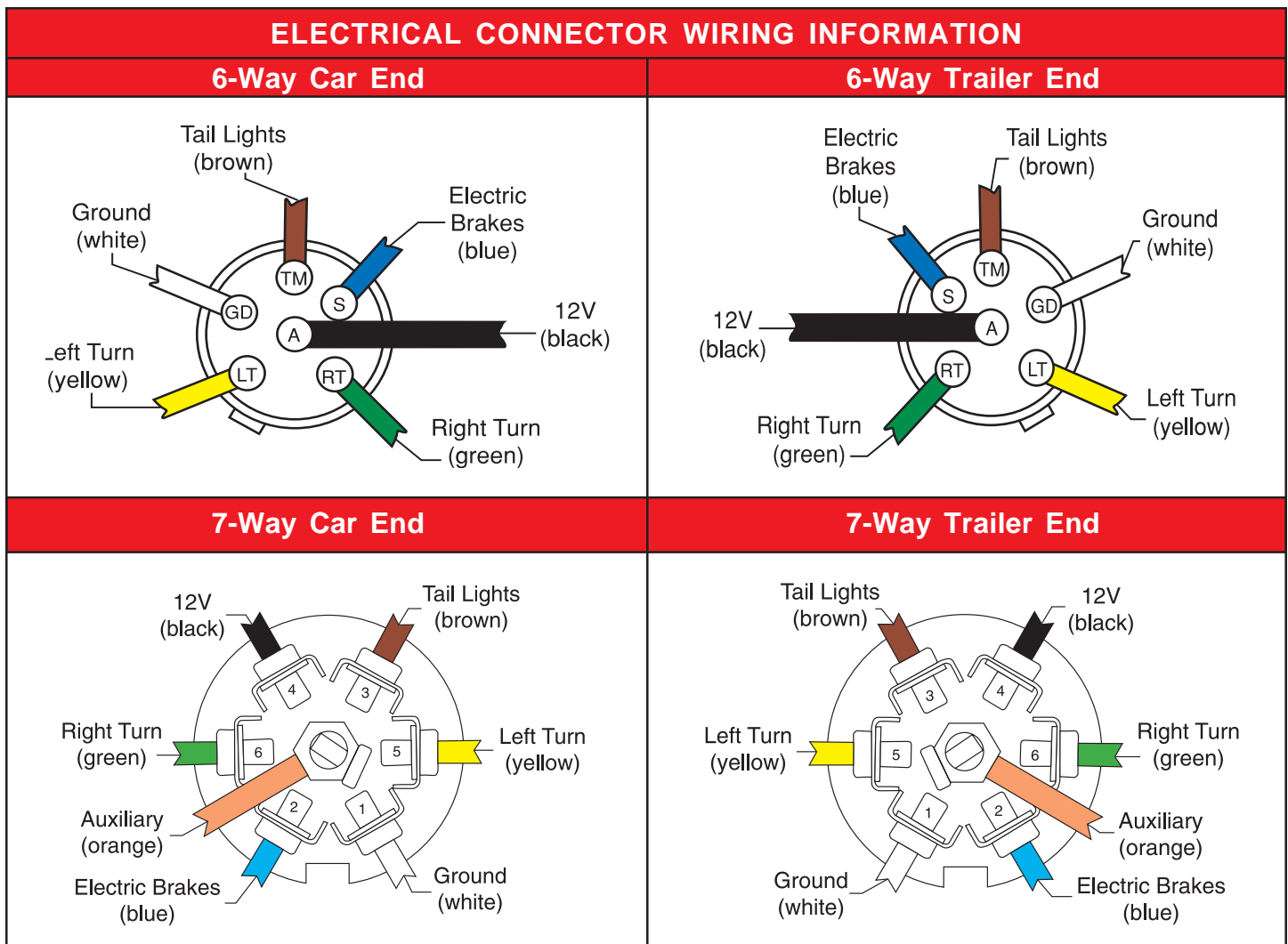

*The bitterness of poor quality remains long after the sweetness of low price disappears.*

**Note: 6 way connectors:** The black (12V) and Blue (Electric Brakes) may be reversed to suit trailer. Horse Trailers may use the center pin for 12V, R.V. trailers use the center for Electric Brakes as (shown).

