



Heavy Duty Gooseneck Low Boy



Artwork for illustration use only.

Standard Features

GVWR.	10,400lb.	G.A.W.R. (each axle)	5,200 lb.
Coupler	2 ⁵ / ₁₆ " Ball Std. Adjustable Pipe	Suspension	Eye-to-Eye 5 Leaf Spring
Safety Chains	³ / ₈ Grade 70 w/Safety Latch Hooks (2 ea.)	Tires	750 x 16 Loadrange D
Jack	(1) 12,000 lb. Drop Leg Jack, Spring Loaded	Spare Tire Mount	Located in Gooseneck
Neck	8" x 11.5 lb. Channel	Wheels	16" x 6" - Modular Wheels
Frame	6" x 8.2 lb. Channel	Floor	Wolmanized 2" x 10"
Cross Members	3" I-Beam @ 24" centers	Lights	D.O.T. Steel Armored
Fenders	Heavy Duty Smooth Steel	Break-Away System	Meets D.O.T. Specifications
Ramps	5 Ft. Slide-in with storage	Safety Marker Tape	Meets D.O.T. Specifications
Axles	(2) Dexter 5,200 lb. with Electric Brake Axles	Electrical	6-Way Insulated Cable
		Finish (prep)	White Phosphorus Washed, Primed 100% Complete with PPG VAP904
		Paint	Exterior (2) Coat System, PPG Industrial





Heavy Duty Gooseneck Low Boy

....Call for Pricing

Trailers:

- 20' x 83" Deck
- 24' x 83" Deck**

Optional:

- Stand-up Removable Ramps
- With or Without 3" Side Rail

Axle Upgrades:

- 5.2K 6H 2 Brake
- 5.2K 8H 1 Brake
- 5.2K 8H 2 Brake
- 6K 6H 1 Brake
- 6K 6H 2 Brake
- 6K 8H 1 Brake
- 6K 8H 2 Brake
- Slipper Springs
- 7K 8H 1 Brake Slipper
- 7K 8H 2 Brake Slipper
- 8K 8H 2 Brake Slipper***

Additional Upgrades:

- Dovetail
- Floor Tie-Downs (each)
- D-Rings (each)
- Smooth Teardrop Fenders
- Treadplate Straight Fenders
- Treadplate Teardrop Fenders
- 3/16" Square Broke Fenders

Tire & Wheel Upgrades:

- (4) 10 Ply Bias
- (4) 10 Ply Radial
- (4) 14 Ply Radial
- Spare 8 Ply Bias
- Spare 10 Ply Bias
- Spare 10 Ply Radial
- Spare 14 Ply Radial

** Trailer has 8" x 11.5 lb channel Mainframe
 ***Trailer frame has 77" maximum width

Prices Subject to Change Without Notice

F.O.B. San Antonio, TX.

The bitterness of poor quality remains long after the sweetness of low price disappears.



Southwest Gooseneck

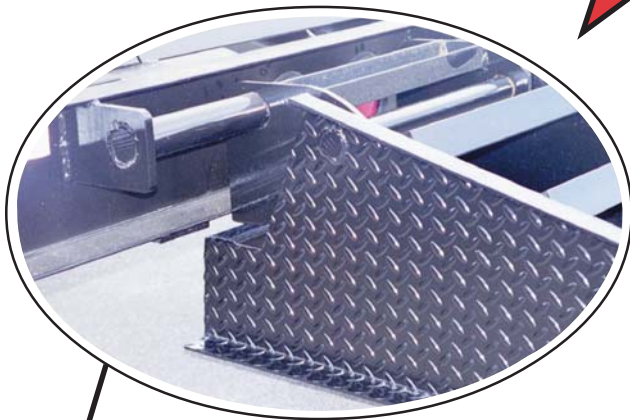

Intergrated Ramp Support



Flatbed Tie down (optional)

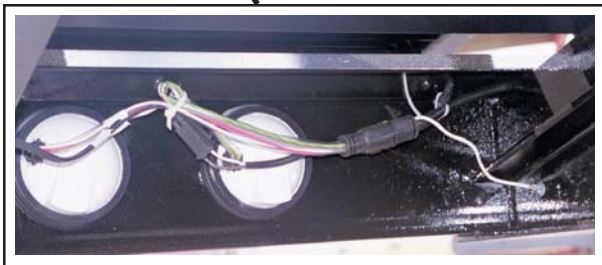

Phillips Sta-Dry Wire Harness



Combination Stake Pockets & D-Rings (optional)



3" Mini I-beam crossmember
3/16" solid gusset with 1" bend



Dexter axles with 3" heavy duty rubber bushed suspension



ELECTRICAL Tips and Diagrams

Wire Installation Tips

By law, trailer lighting must be connected into the tow vehicle's wiring system to provide trailer running lights, turn signals and brake lights. This is accomplished by tapping into the tow vehicle's harness power to the trailer wiring system. Connectors are used between the two to allow disengagement when not towing.

Connectors

Various styles of connectors are available with four to seven pins to allow transfer of power for the lighting as well as auxiliary functions such as electric trailer brake control, backup lights, etc. Choose a connector that has the required number of pins for the functions required. The male end is mounted on the vehicle side and the female end on the trailer side.

6 Way Connectors

Round 1 1/4" diameter metal conductors are available that allow 1 or 2 additional functions such as back up lights and electric brakes.

7 Way Connectors

Additional pins for auxiliary power, trailer battery charging, etc. are available using larger 2" diameter, round connectors.

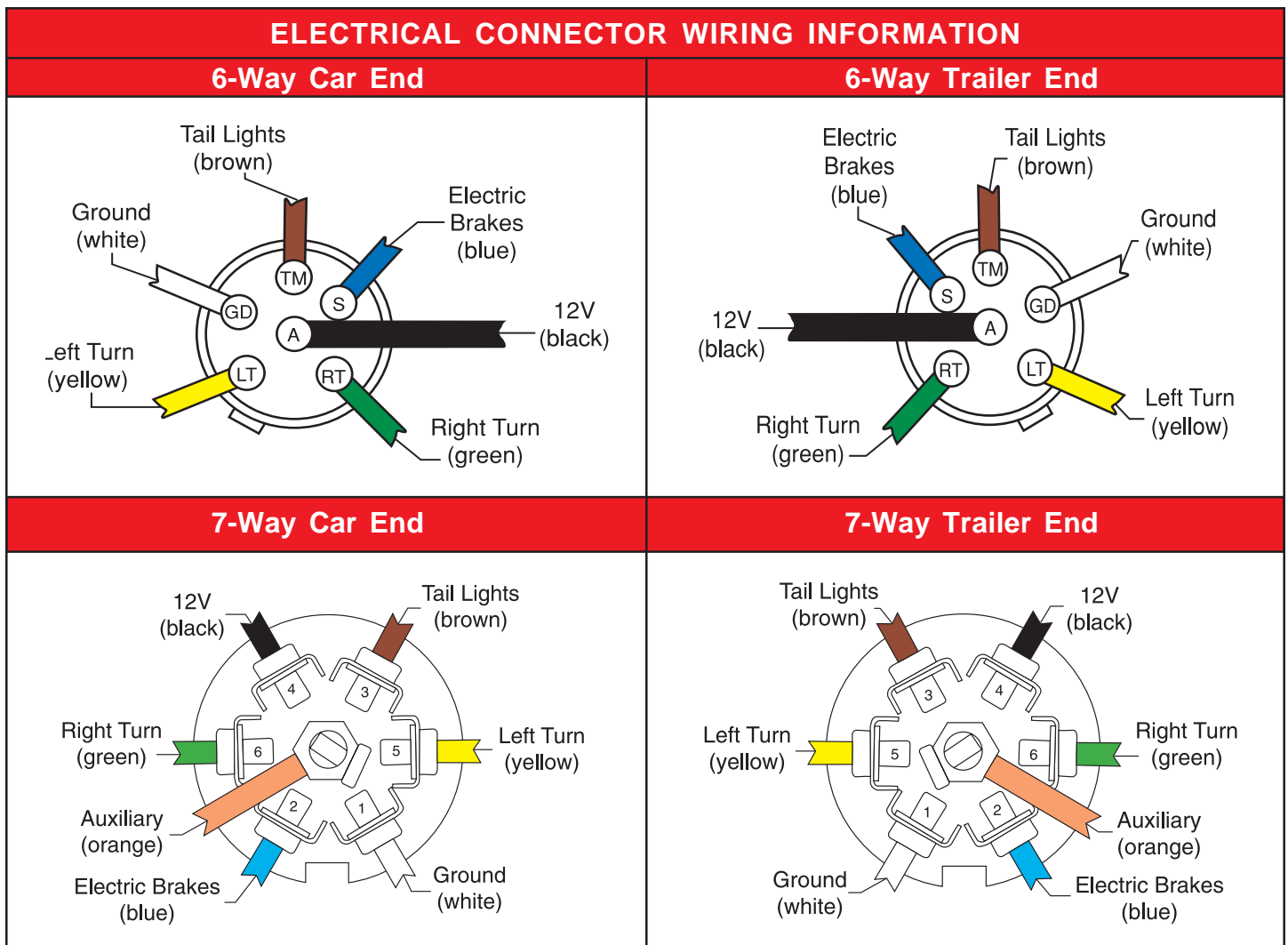

The bitterness of poor quality remains long after the sweetness of low price disappears.

Note: 6 way connectors: The black (12V) and Blue (Electric Brakes) may be reversed to suit trailer. Horse Trailers may use the center pin for 12V, R.V. trailers use the center for Electric Brakes as (shown).

